

VIEWTECH VII & VIII BAR END MIRRORS

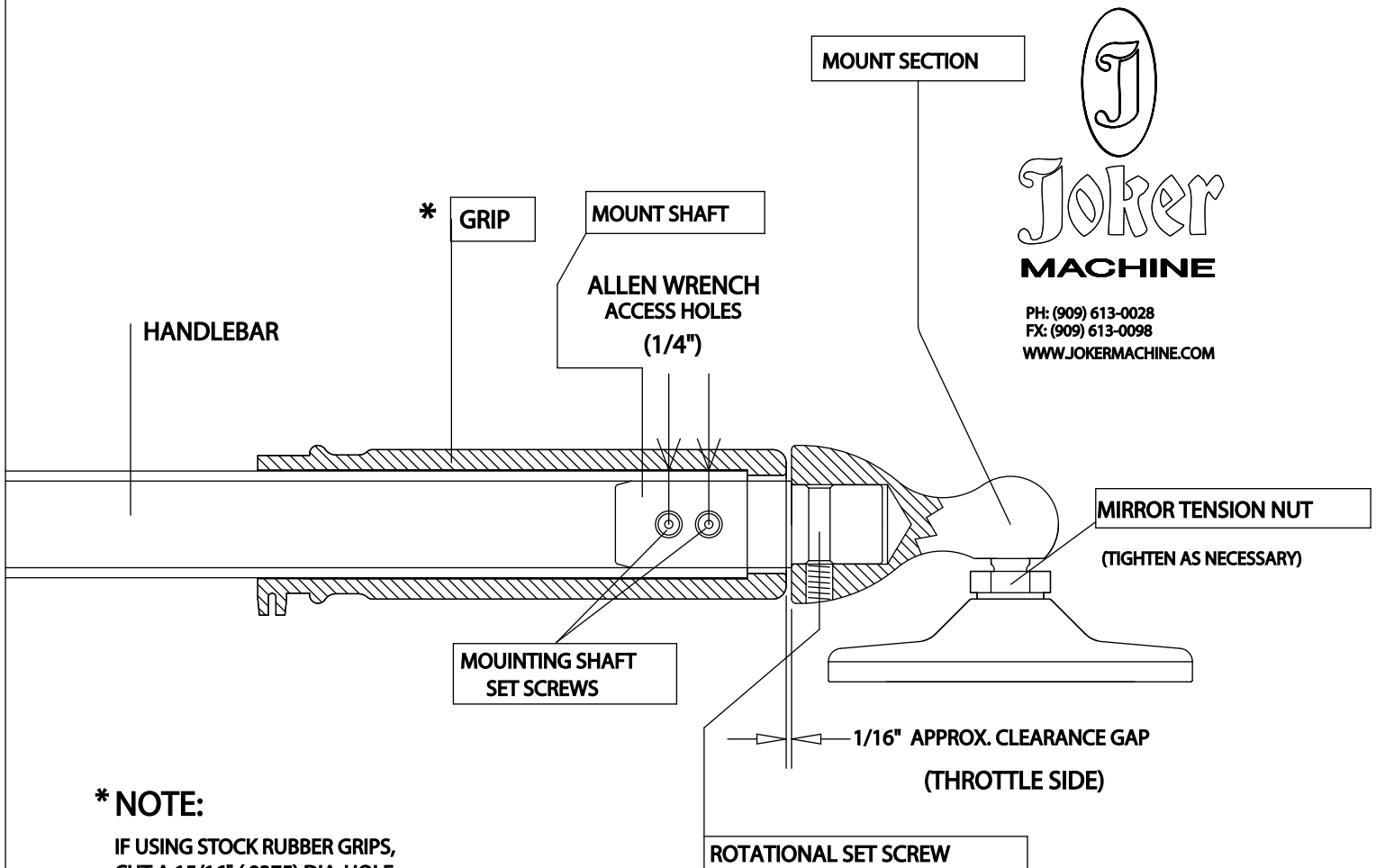
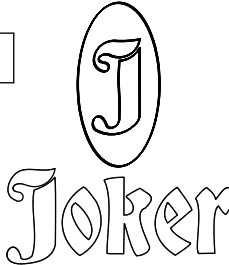

Joker
MACHINE
 PH: (909) 613-0028
 FX: (909) 613-0098
 WWW.JOKERMACHINE.COM

*** NOTE:**

IF USING STOCK RUBBER GRIPS,
 CUT A 15/16" (.9375) DIA. HOLE
 AS PRECISELY AS POSSIBLE INTO GRIP ENDS.

(USE LOCTITE ON ALL FASTENERS)

BILL OF MATERIALS

- 1) Mirror Head
- 1) Mirror Mount Section
- 1) Mount Shaft
- 1) Tension Nut
- 1) Ball Stem
- 1) Plastic Spacer
- 1) 1/4"-20 x 1/4" Set Screw
- 2) 10-24 x 1/2" Set Screw

INSTALLATION

1. Place hand grip onto handlebar and determine the correct spacing between the mount section and the end of the grip.
2. After inserting the mounting shaft into the bar, take note on where to drill the 1/4" dia. access holes.

NOTE: * ONLY DRILL THRU ONE WALL OF BAR
*** DE-BURR THE HOLES INSIDE AND OUT**

3. Tighten set screw in mounting shaft.
4. Slide grip into position and assemble as normal.
5. Slide mount section and mirror assembly onto mounting shaft
6. Rotate mirror assembly to desired position and tighten set screw.
7. Repeat the process on the stationary (left) grip side.